

References





5



19



31



61



71



91



95



103



109



113



117



05 L'Enversin

VAUJANY

1250 - 3330 m Station village

L'Enversin 02

Alpe d'Huez
grand domaine Ski



Gondola Lifts

GLD 10 Narvikfjellet / NO	6
GLD 8 Gangwha / KR	8
GLD 8 Vaujany / FR	10
GLD 8 Vivaldi Park / KR	12
GLD 8 Lorica / IT	14
GLD 8 Churwalden-Heidbüel / CH	16

GLD 10 Narvikfjellet

Narvik | NO | 2018

 1171 m

 8

Design by
**PORSCHE DESIGN
STUDIO**

 439 m

 38

 653 kW

 2400 p/h



6





GLD 8 Gangwha

Gangwha | KR | 2018

↗ 640 m

7

Design by
**PORSCHE DESIGN
STUDIO**

↕ 149 m

30

⚡ 263 kW

👤 2400 p/h





GLD 8 Vaujany

Vaujany | FR | 2017

 574 m

 4

Design by
**PORSCHE DESIGN
STUDIO**

 112 m

 25

 155 kW

 2000 p/h

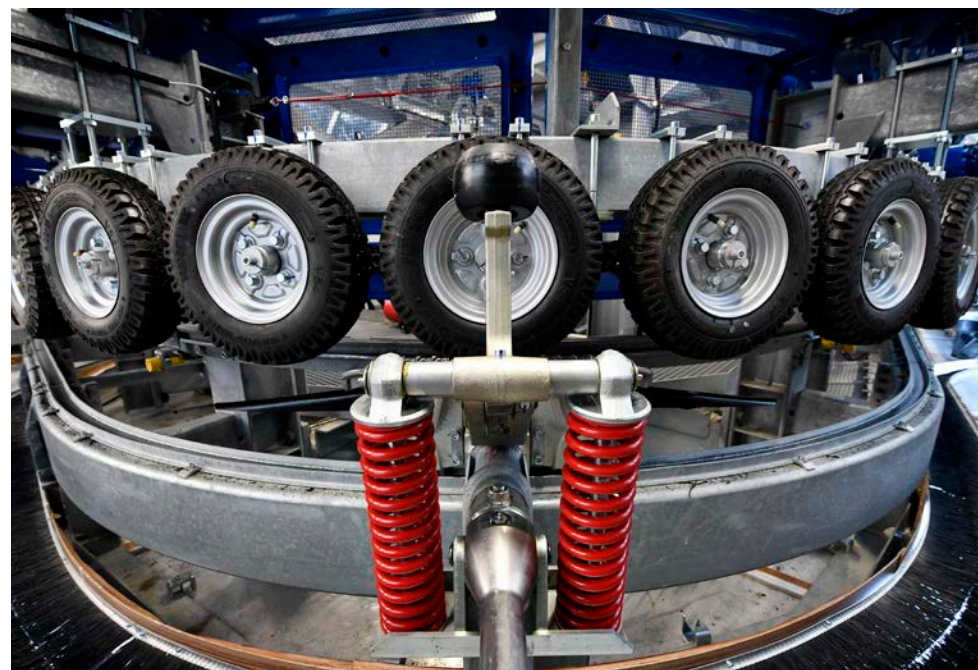



BARTHOLET

08 L'Enversin
VAUJANY



GLD 8 Vivaldi Park

Gangwondo | KR | 2017

↗ 941 m

7

Design by
PORSCHE DESIGN
STUDIO

↕ 189 m

33

⚡ 139 kW

👤 1300 p/h





GLD 8 Lorica

Lorica | IT | 2017

 2192 m  14

 470 m  46

 469 kW

 1600 p/h

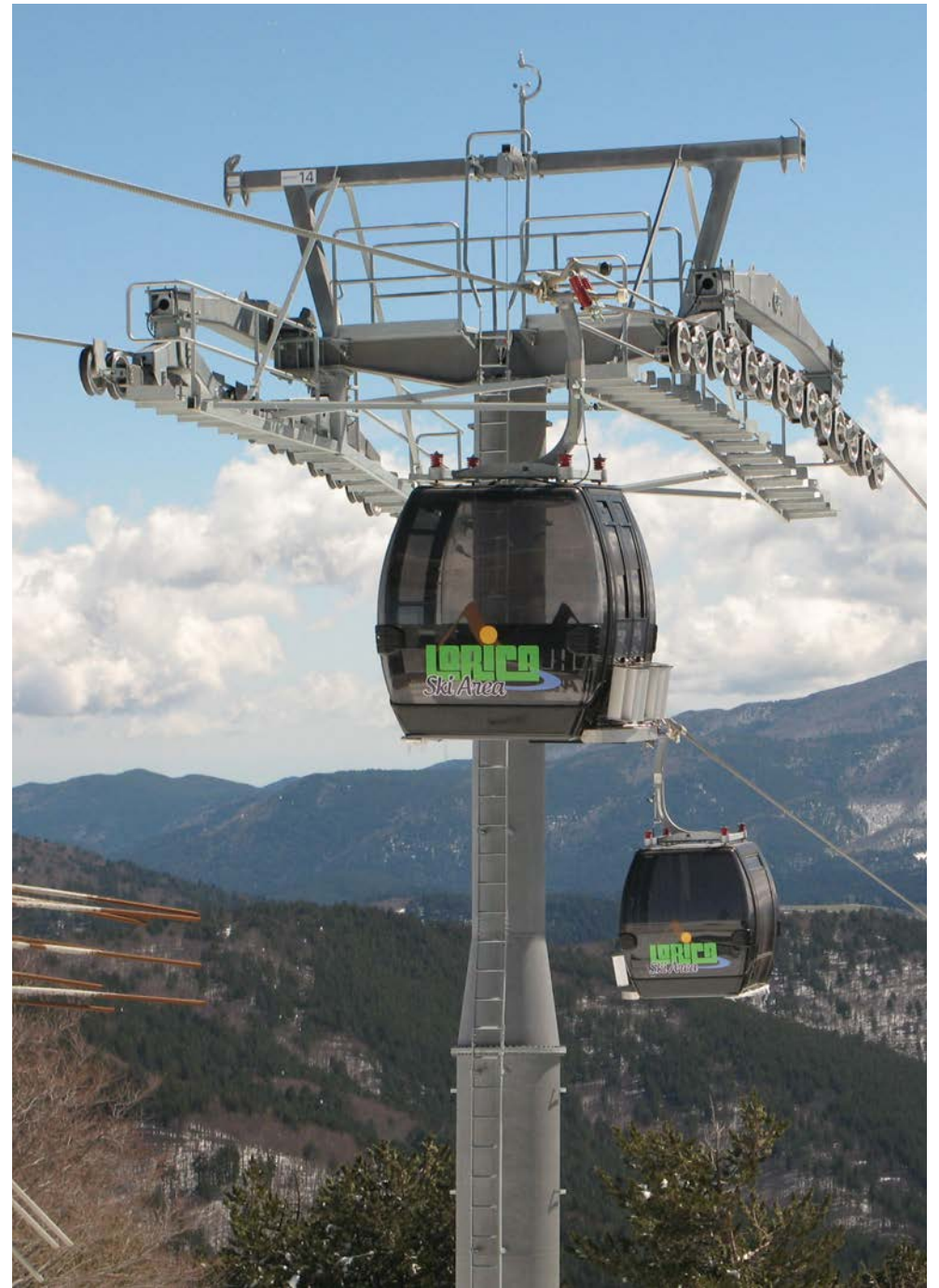
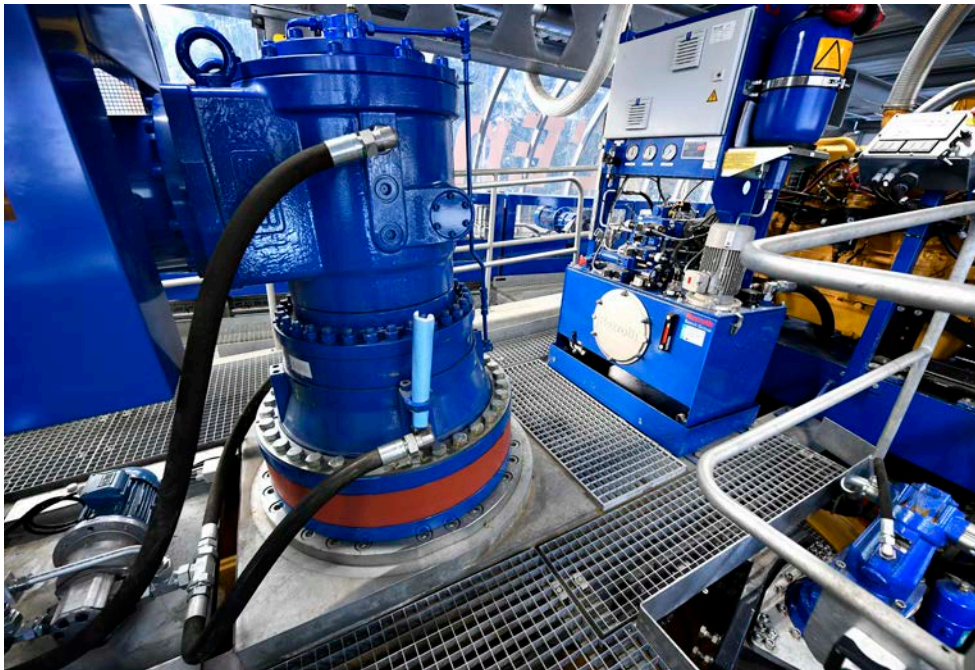



GLD 8 Churwalden-Heidbüel

Lenzerheide | CH | 2015

↗ 1778 m

⌋ 12

Design by
**PORSCHE DESIGN
STUDIO**

↕ 687 m

⊙ 57

⚡ 679 kW

👤 2200 p/h

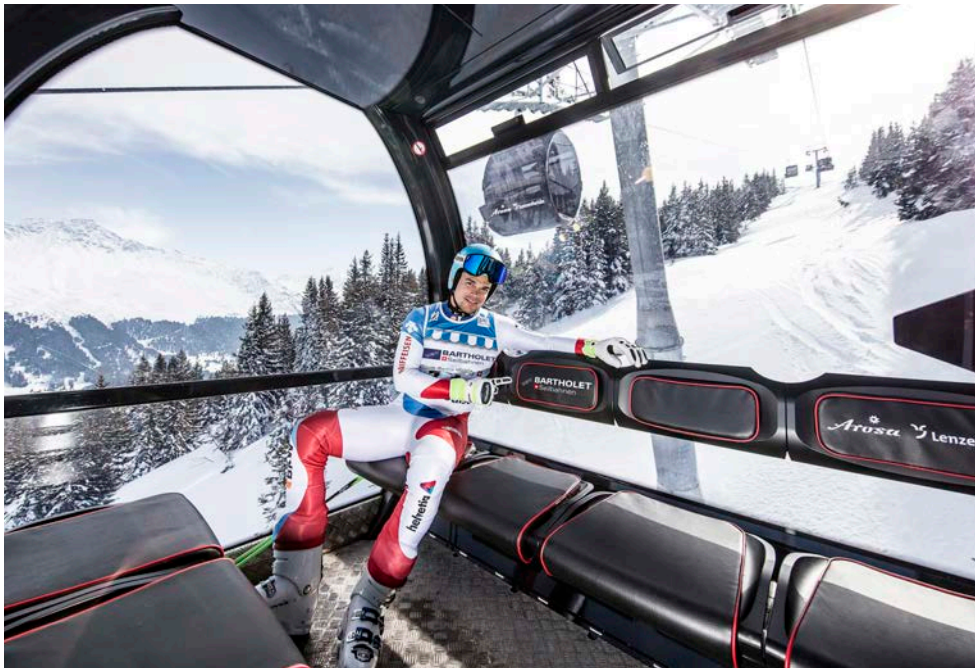
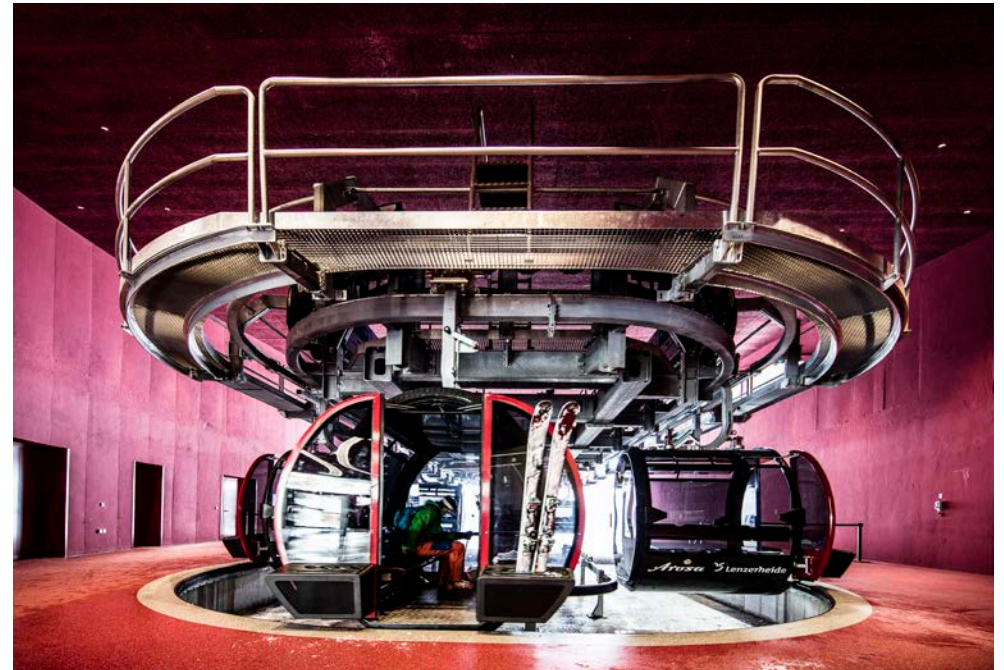







Téléporté Mixte

TPM 4/8 Moscow / RU	20
TPM 4/8 Kopa-Karpacz / PL	22
TPM 6/8 Altay / CN	24
TPM 4/8 Kirovsk / RU	26
TPM 4/8 La Berra / CH	28

TPM 4/8 Vorobyovy Gory

Moscow | RU | 2018

 707 m  9

 60m  10

 120 kW  35

 1600 p/h







Design by
**PORSCHE DESIGN
STUDIO**





TPM 4/8 Kopa-Karpacz

Karpacz | PL | 2018

	2281 m		17
	530 m		42
	382 kW		21
	1200 p/h		





TPM 6/8 Altay

Altay | CN | 2018

 1484 m  13

 406 m  60

 414 kW  15

 1950 p/h





TPM 6/8 Kirovsk

Kirovsk | RU | 2015

 1616 m  13

 438 m  36

 514 kW  36

 2400 p/h

Design by
**PORSCHE DESIGN
STUDIO**











BARTHOLET
Seilbahnen

TPM 4/8 La Berra

La Berra | CH | 2013

 2202 m	 17
 596 m	 80
 590 kW	 10
 1500 p/h	







MONT CORBIER

Sybelles
.ski

BARTHOLET
Ropeways



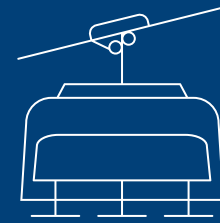

Chair Lifts – Detachable

CLD 6 Thaiwoo / CN	32
CLD 6 Le Corbier / FR	34
CLD 6 Mont Valaisan / FR	36
CLD 6 Moulins Express / FR	37
CLD 6 Lauchernalp-Stafel / CH	38
CLD 6 Bjelasnica / BA	40
CLD 6 Schwamm-Wissi Stei / CH	42
CLD 6 Alp Surlej-Curtinellas / CH	44
CLD 6 Oberalp-Calmut / CH	46
CLD 6 Boismint / FR	48
CLD 6 Bondolero / IT	50
CLD 6 Rusinski / PL	52
CLD 6 Lavadinas-Fuorcla Sura / CH	54
CLD 6 Fontaine Froide / FR	56
CLD 6 Złoty Groń / PL	58

CLD 6 Thaiwoo

Thaiwoo | CN | 2019

 1120 m  14

Design by
**PORSCHE DESIGN
STUDIO**

 132 m  57

 312 kW

 2400 p/h

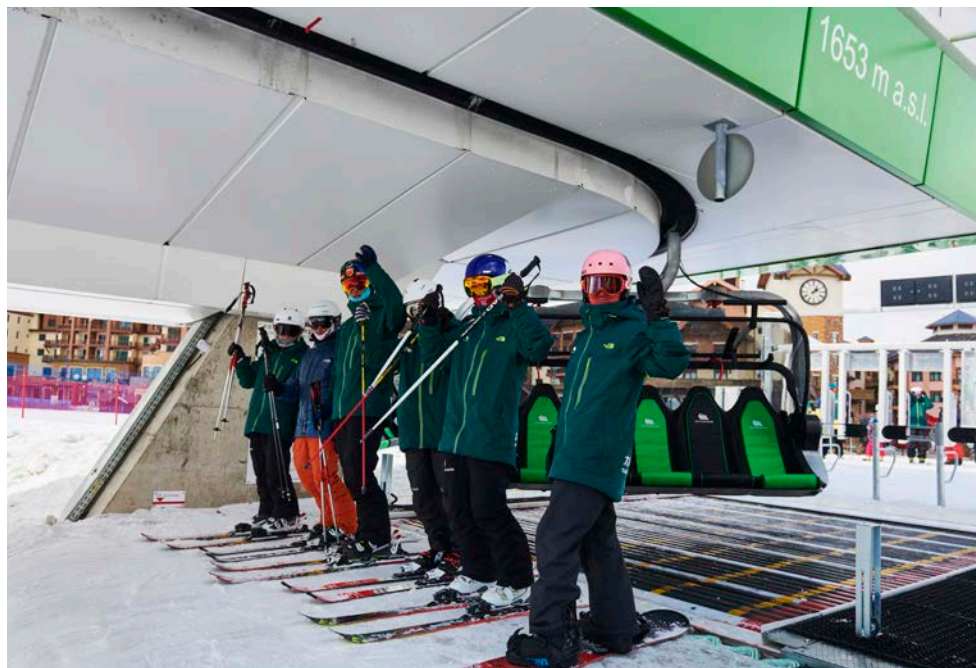



CLD 6 Le Corbier

Le Corbier | FR | 2018

 1754 m  15

 570 m  86

 692 kW

 3000 p/h

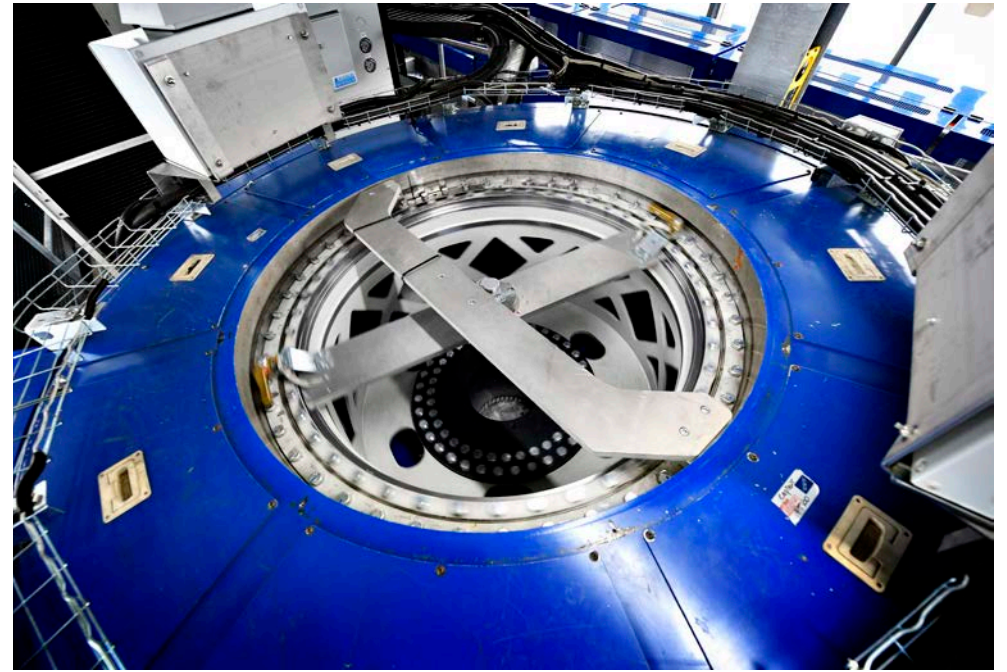



CLD 6 Mont Valaisan

La Rosière | FR | 2018

 876 m  9

 344 m  43

 368 kW

 2400 p/h



36



CLD 6 Moulins Express

La Rosière | FR | 2018

 1648 m  14

 522 m  82

 667 kW

 2800 p/h



CLD 6 Lauchernalp-Stafel

Lauchernalp | CH | 2017

 623 m  7

 148 m  30

 204 kW

 2200 p/h





Lauchernalp
BERGBAHNEN

Lauchernalp
1965m

CLD 6 Bjelasnica

Sarajevo | BA | 2017

 2023 m  13

 603 m  65

 496 kW

 1800 p/h





CLD 6 Schwamm-Wissi Stei

Pizol-Bad Ragaz | CH | 2016

 1669 m

 12

Design by
**PORSCHE DESIGN
STUDIO**

 520 m

 53

 510 kW

 1580 p/h











1853m ü. M. pizol

BARTHOLET

CLD 6 Alp Surlej-Curtinellas

Silvaplana | CH | 2016

	2145 m		17	Design by PORSCHE DESIGN STUDIO
	482 m		85	
	671 kW			
	2400 p/h			





CLD 6 Oberalp-Calmut

Sedrun | CH | 2016

 966 m

 10

Design by
**PORSCHE DESIGN
STUDIO**

 258 m

 46

 311 kW

 2400 p/h





CLD 6 Boismint

Val Thorens | FR | 2016

 1835 m  15

 591 m  85

 624 kW

 2600 p/h





CLD 6 Bondolero

San Domenico | IT | 2014

 1069 m  10

 287 m  52

 334 kW

 2400 p/h

Design by
**PORSCHE DESIGN
STUDIO**





BARTHOLET
Seilbahnen 2488 m

SANDOMENICO Ski

CLD 6 Rusinski

Bukowina | PL | 2014

 961 m

 9

Design by
**PORSCHE DESIGN
STUDIO**

 176 m

 54

 296 kW



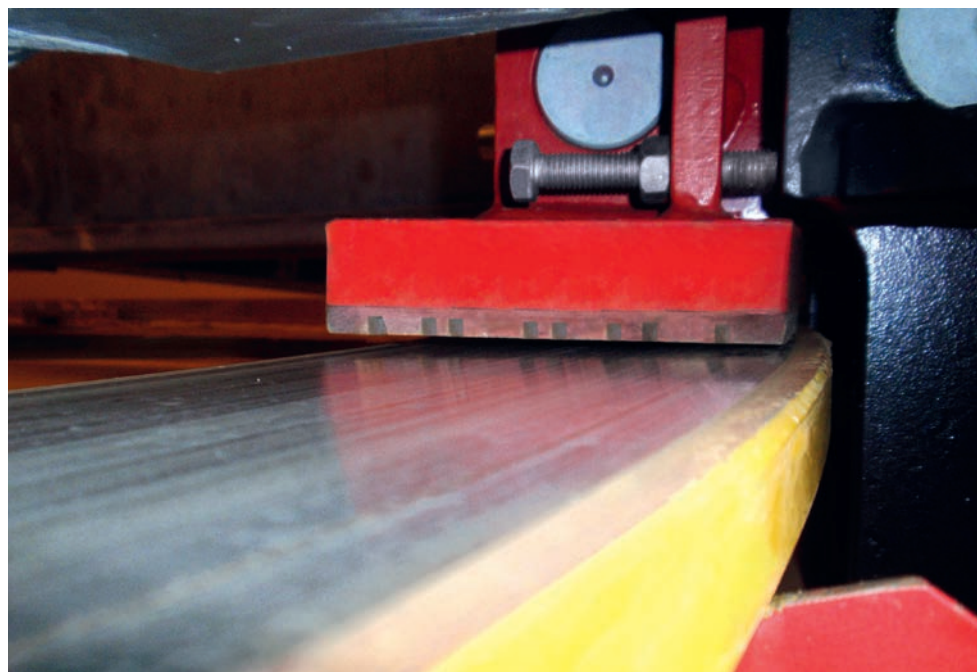



 2790 p/h





CLD 6 Lavadinas-Fuorcla Sura

Laax | CH | 2012

-  2143 m
 -  19
 -  624 m
 -  86
 -  783 kW
 -  2400 p/h
- Design by
**PORSCHE DESIGN
STUDIO**





CLD 6 Fontaine Froide

Val d'Isère | FR | 2012

 1186 m  10

 305 m  66

 403 kW

 3000 p/h







Fontaine Froide

Val d'Isère

CLD 6 Złoty Groń

Złoty Groń | PL | 2012

 746 m  7

 152 m  38

 240 kW

 2800 p/h

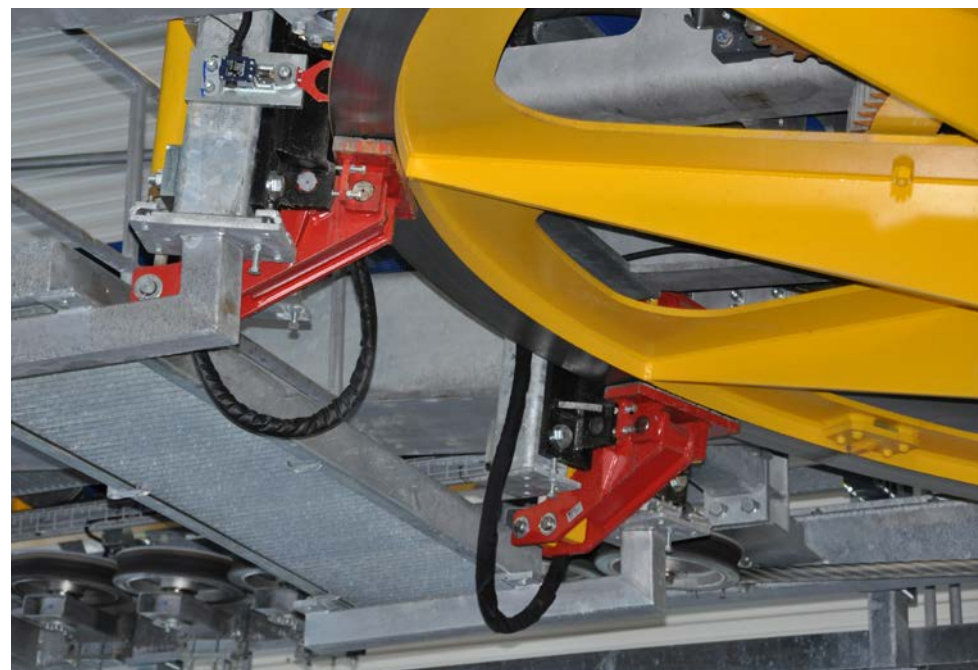



ZEOTYCRON





Chair Lifts – Fix

CLF 4 Bjelasnica / BA	62
CLF 4 Lorica / IT	63
CLF 4 Mandra / CH	64
CLF 4 Lenzerheide Ost-West / CH	65
CLF 4 Bocksberg / DE	66
CLF 4 Poniwiec / PL	67
CLF 4 Lustyk / PL	68
CLF 4 Kirovsk / RU	69

CLF 4 Bjelasnica

Sarajevo | BA | 2017

 561 m  6

 195 m  21

 53 kW

 600 p/h



62



CLF 4 Lorica

Lorica | IT | 2017

 848 m  8

 228 m  62

 110 kW

 1200 p/h



CLF 4 Mandras

Silvaplana | CH | 2015

 722 m  8

 165 m  70

 110 kW

 1800 p/h



CLF 4 Lenzerheide Ost-West

Lenzerheide | CH | 2015

 583 m  7

 5 m  38







 28 kW

 1200 p/h



CLF 4 Bocksberg

Hahnenklee | DE | 2014

-  943 m
-  10
-  173 m
-  121
-  154 kW
-  2400 p/h



CLF 4 Poniwiec

Ustroń | PL | 2014

↗ 803 m



9

↕ 234 m



72

⚡ 135 kW

👤 1475 p/h

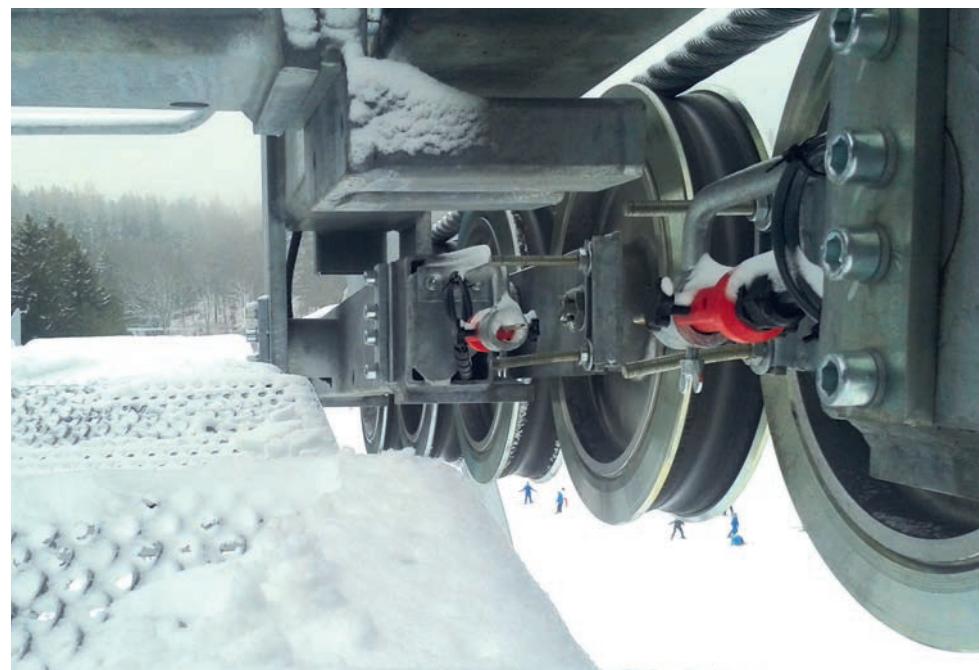

CLF 4 Lustyk

Karpacz | PL | 2014

 330 m  5

 57 m  41

 61 kW

 2250 p/h



CLF 4 Kirovsk

Kirovsk | RU | 2013

 1066 m  13

 246 m  118

 160 kW

 1750 p/h





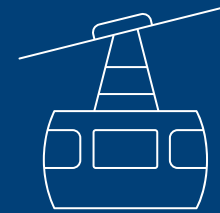

Aerial Tramways

AT 8 Frümsen / CH	72
AT 60 Brest / FR	74
AT 15 Le Dahu / FR	76
AT 35 Puebla / MX	78
AT 35 Gemmi / CH	80
AT 60 Moléson / CH	82
AT 25 Durango / MX	84
AT 15 Vetruse / CZ	86
AT 45 Chur-Känzeli / CH	88

AT 8 FrümSEN

Sennwald | CH | 2018

 2280 m

 3

Design by
**PORSCHE DESIGN
STUDIO**

 1238 m

 2 à 8 p

 51 kW

 72 p/h





AT 60 Brest

Brest | FR | 2016

 419 m

 1

 7 m

 2 à 60 p

 318 kW







 1220 p/h





AT 15 Le Dahu

Les Arcs | FR | 2016







-  457 m
-  2
-  98 m
-  2 à 15 p
-  42 kW
-  325 p/h





AT 35 Puebla

Puebla | MX | 2015



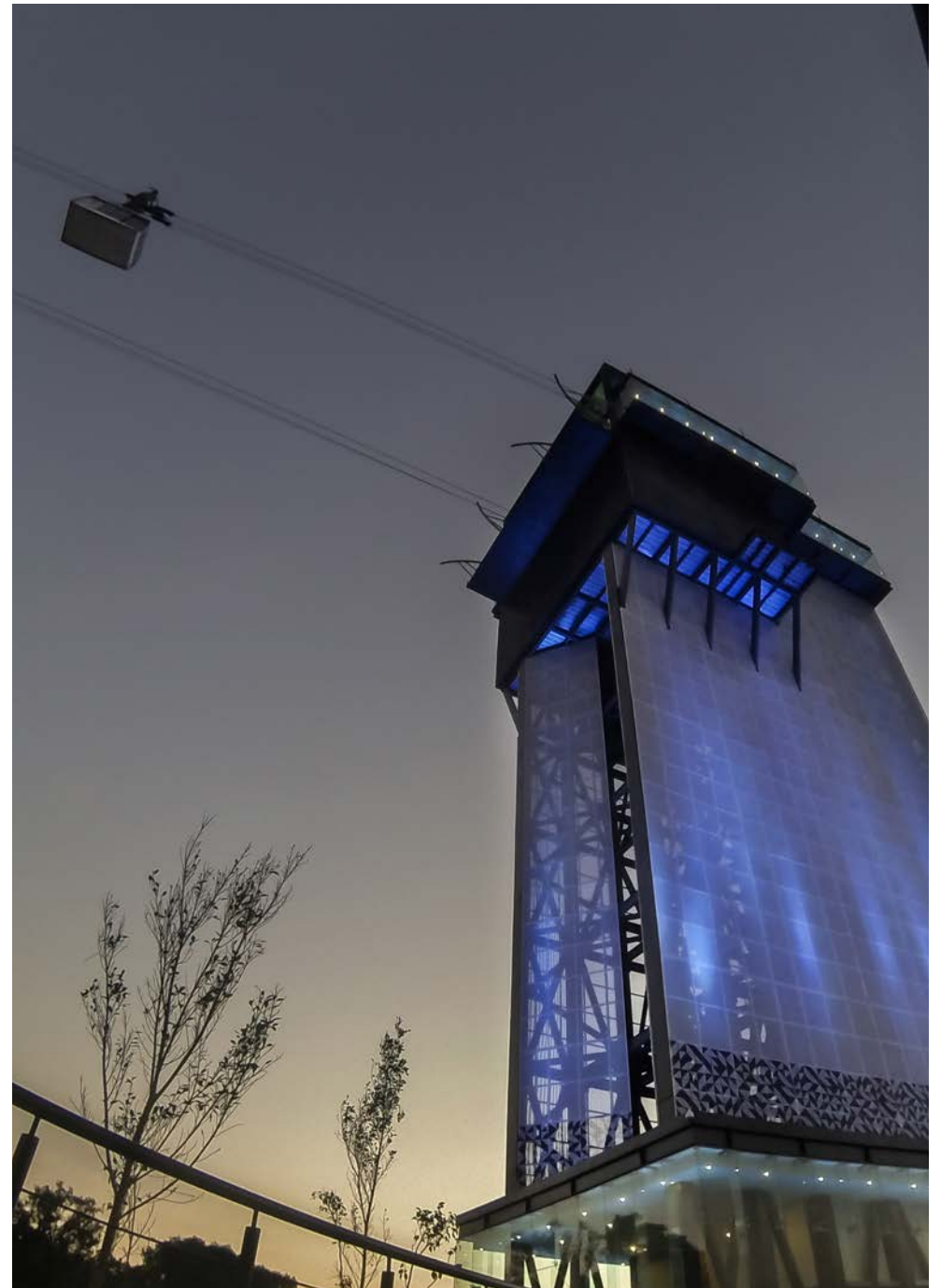



-  660 m
-  0
-  37 m
-  2 à 35 p
-  65 kW
-  692 p/h





AT 35 Gemmi

Leukerbad | CH | 2012

-  1967 m
-  1
-  920 m
-  2 à 35 p
-  216 kW
-  328 p/h





AT 60 Moléson

Moléson | CH | 2011

 1095 m

 1

 459 m

 2 à 60 p

 243 kW

 692 p/h





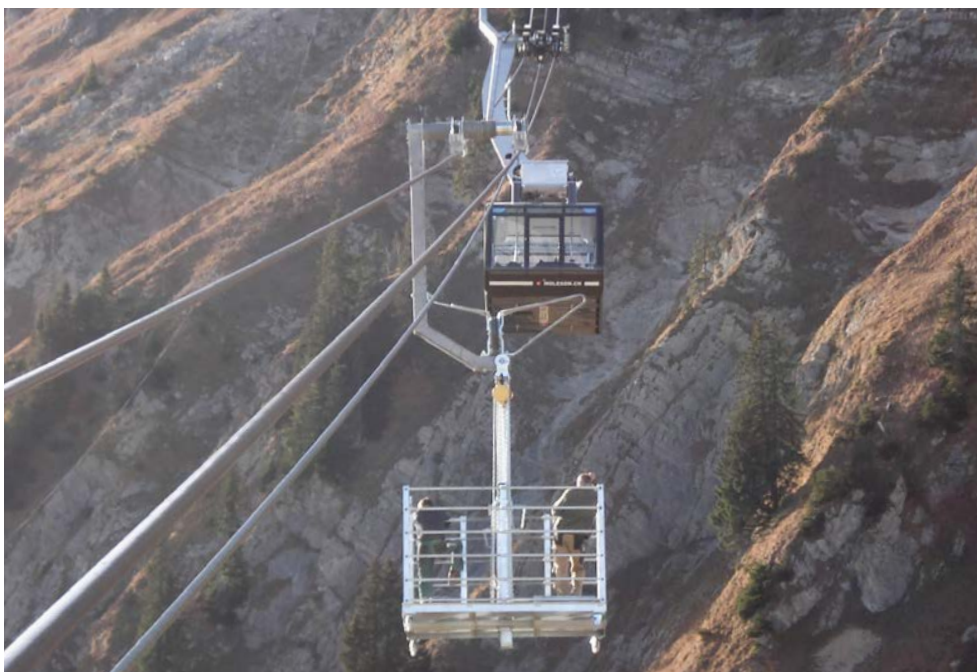



82





AT 25 Durango

Durango | MX | 2010

-  663 m
-  1
-  72 m
-  2 à 25 p
-  60 kW
-  336 p/h





AT 15 Vetruse

Vetruse | CZ | 2010

 325 m

 0

 50 m

 2 à 15 p

 30 kW



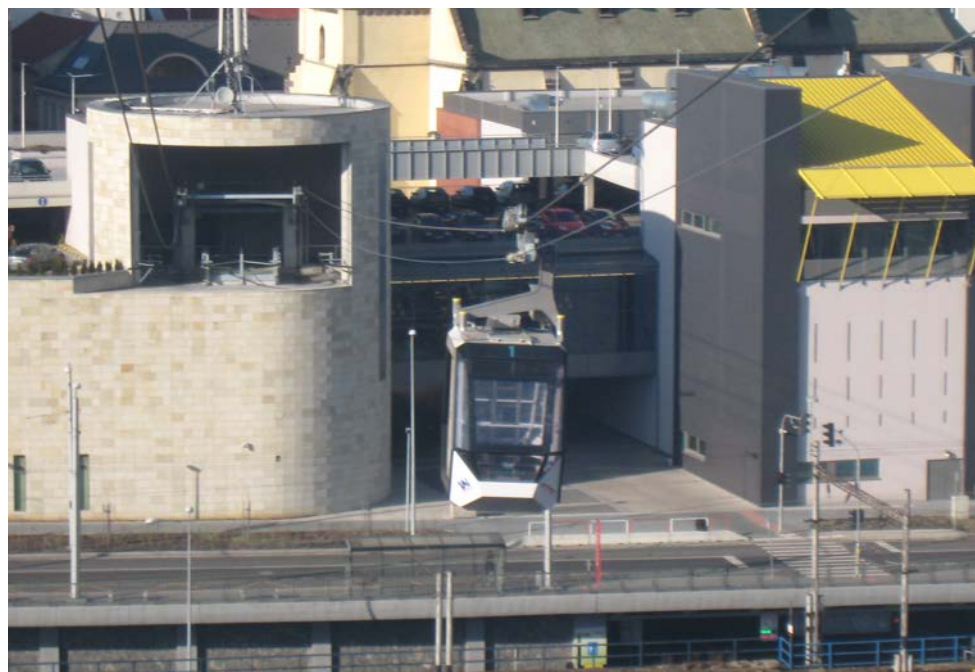



 390 p/h





AT 45 Chur-Känzeli

Chur | CH | 2006

-  1098 m
-  1
-  594 m
-  2 à 45 p
-  294 kW
-  600 p/h

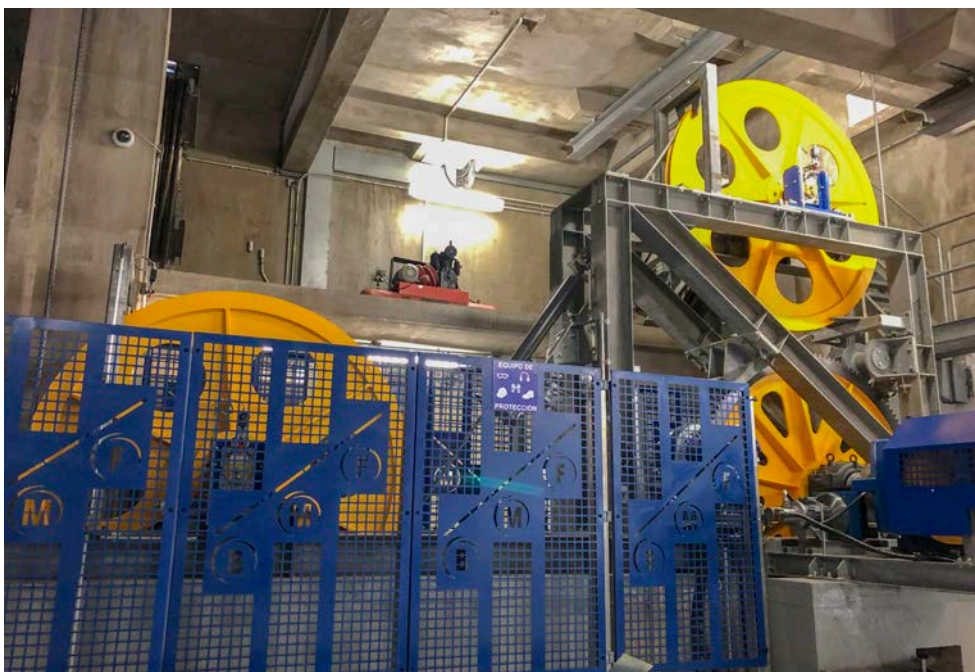







Funitel





FU 40 De Thorens / FR

92

91

FU 40 De Thorens

Val Thorens | FR | 2011

-  780 m
-  5
-  211 m
-  2x2 à 33 p
-  1710 p/h

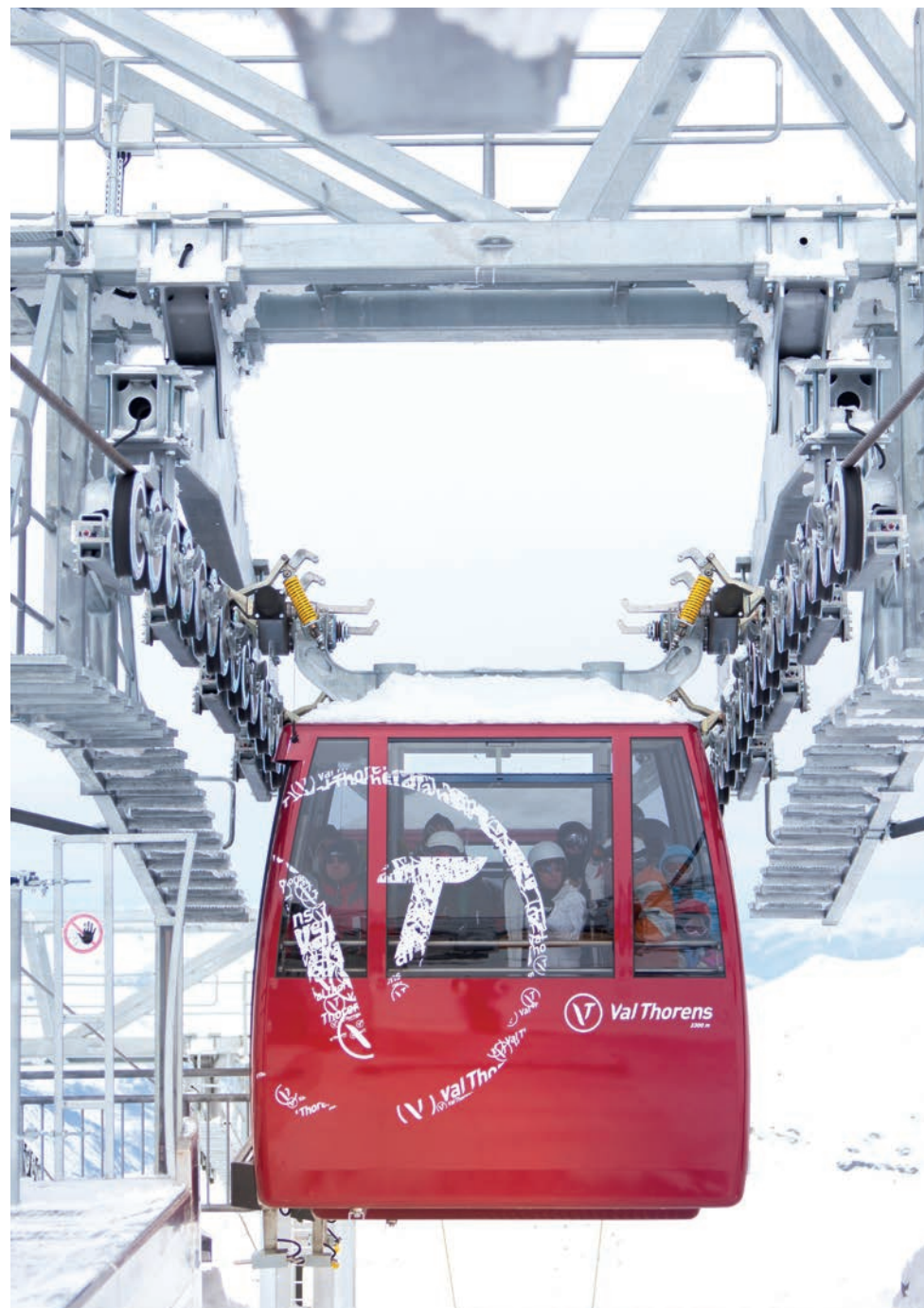







Group Lifts

GRL 2x3x6 C3ndor Andino / CL	96
GRL 2x3x10 Akvapark / LT	98
GRL 2x3x18 Limon / CR	100
GRL 2x3x6 Monteverde / CR	101

GRL 2x3x6 Cóndor Andino

National Park Huilo Huilo | CL | 2016

 1357 m

 7

 594 m

 2x3 à 6 p

 123 kW







 110 p/h





GRL 2x2x10 Akvapark

Druskininkai | LT | 2015







-  1180 m
-  5
-  24 m
-  2x2 à 10 p
-  104 kW
-  222 p/h





GRL 2x2x18 Limon







Limon | CR | 2007

-  421 m
-  6
-  192 m
-  2x2 à 18 p
-  90 kW
-  340 p/h



GRL 2x2x6 Monteverde

Monteverde | CR | 2006

-  751 m
-  5
-  174 m
-  2x2 à 6 p
-  90 kW
-  432 p/h







Inclined Lifts

IL 15 Chamonix Funi 2000 / FR	104
IL 12 Gdynia / PL	106
IL 8 Leisee-Sunegga / CH	107

IL 15 Chamonix Funi 2000

Chamonix | FR | 2015

 73 m  1 à 15 p

 36 m

 45 kW

 356 p/h



104

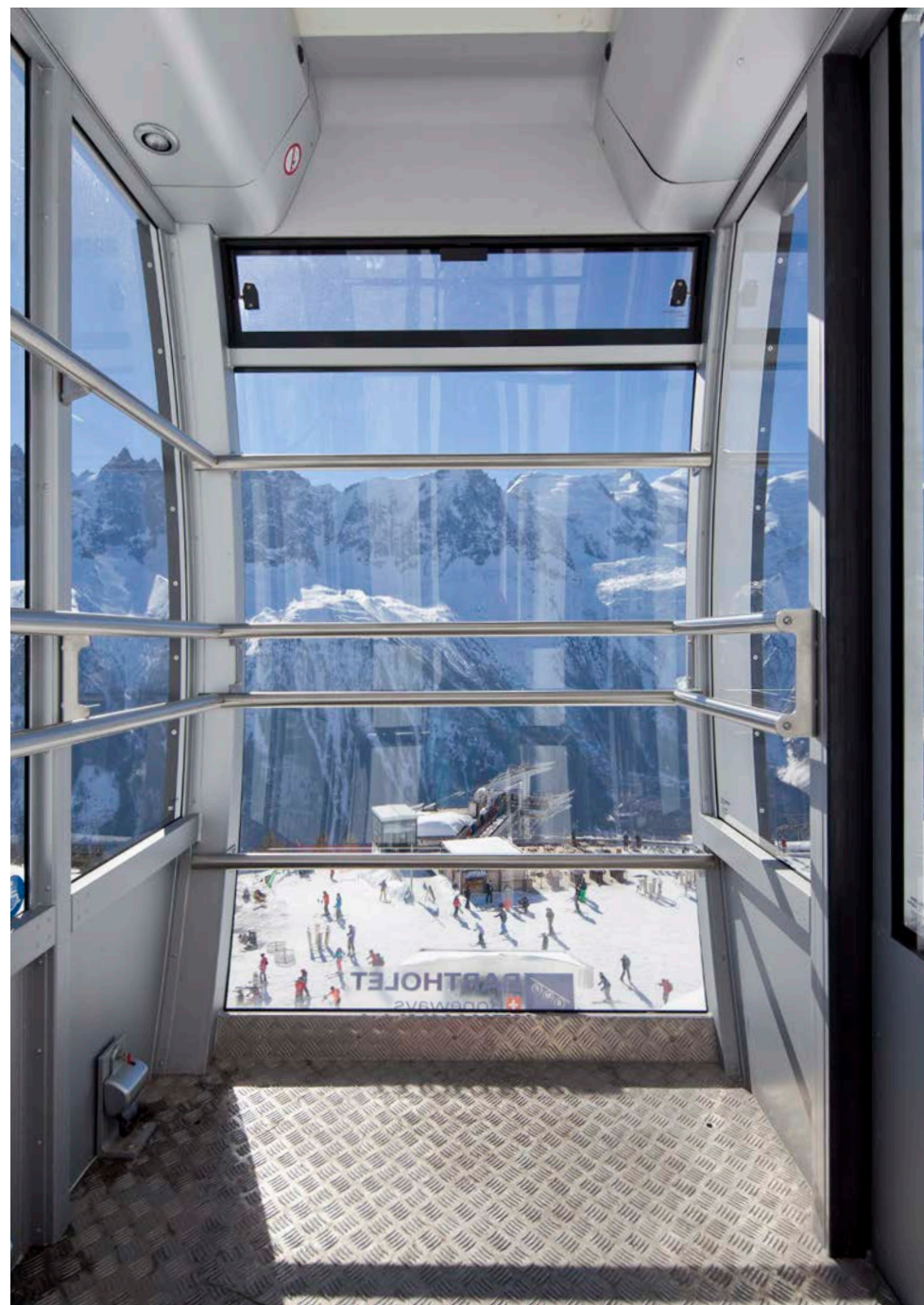



COMPAGNIE DU
MONT BLANC

IL 12 Gdynia

Gdynia | PL | 2015

 96 m  1 à 12 p

 39 m

 55 kW

 233 p/h



106



IL 8 Leisee-Suneggga

Zermatt | CH | 2008

 80m  2 à 8p

 43m

 55 kW

 240 p/h





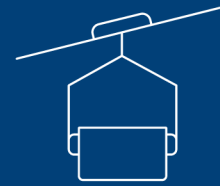

Material Lifts

ML Rigips / AT

110

109

ML Rigips

Bad Aussee | AT | 2017

↗ 8400 m ⚙ 41
↕ 85 m ⚙ 182







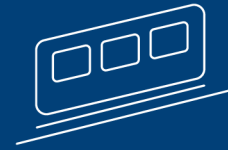

Funicular Railways

FR 250 Vadistanbul / TR

114

113

FR 250 Vadistanbul

Istanbul | TR | 2017

↔ 750 m  2 à 250 p

↕ 40 m

 3500 p/h



114

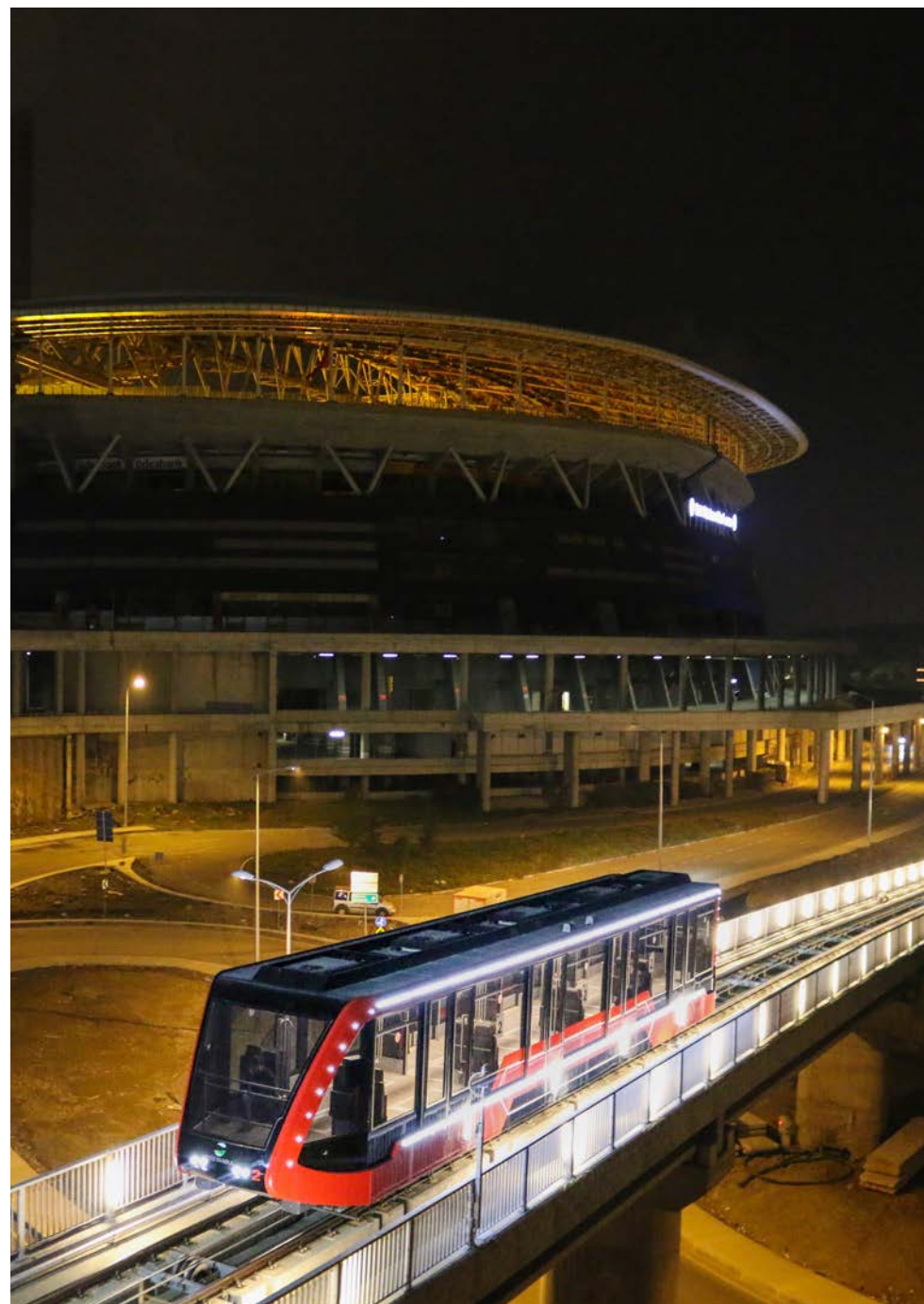



Radisson

VIA ST NBI YA AG 451

Česká republika

První banka



Bartholet Metallbau AG
Seilbahnen
8890 Flurns
☎ 081-720 10 60

ⓑ Ⓜ Ⓣ



Ski Lifts

SL Wittenen / CH	118
SL Presanella / IT	119
SL Tenna Solarskilift / CH	120

SL Wittenen

Kandersteg | CH | 2016

 662 m  9

 126 m  62

 65 kW

 1000 p/h

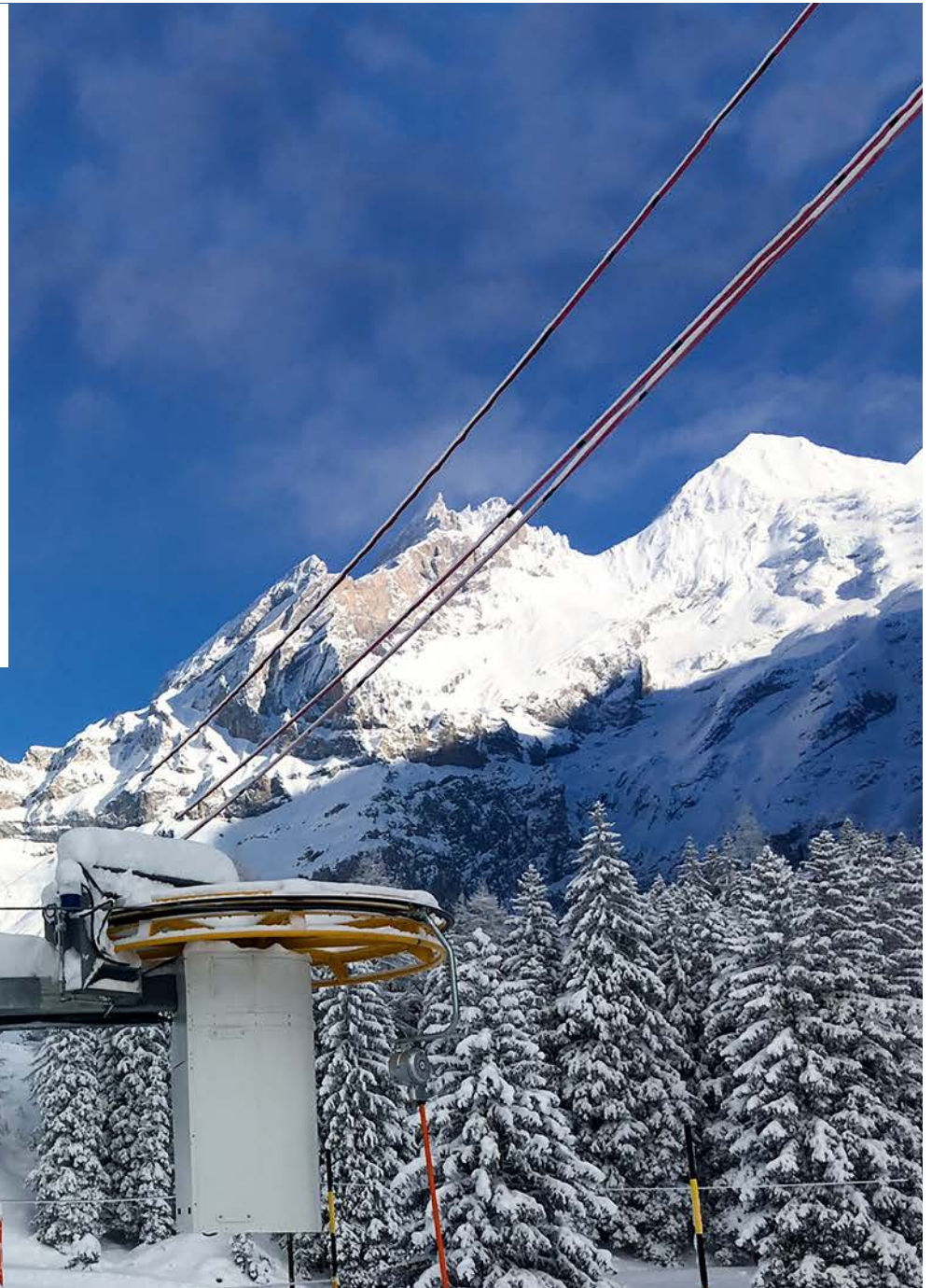

SL Presanella

Adamello | IT | 2012

 299 m  4

 27 m  54

 18 kW

 850 p/h



SL Tenna Solarskilift

Tenna | CH | 2011

 465 m  5

 135 m  35

 44 kW

 800 p/h

T
—
120

Energy production compared to consumption

Production today

349 kWh

Consumption today

55,3 kWh

Production Skilift 

Consumption Skilift 

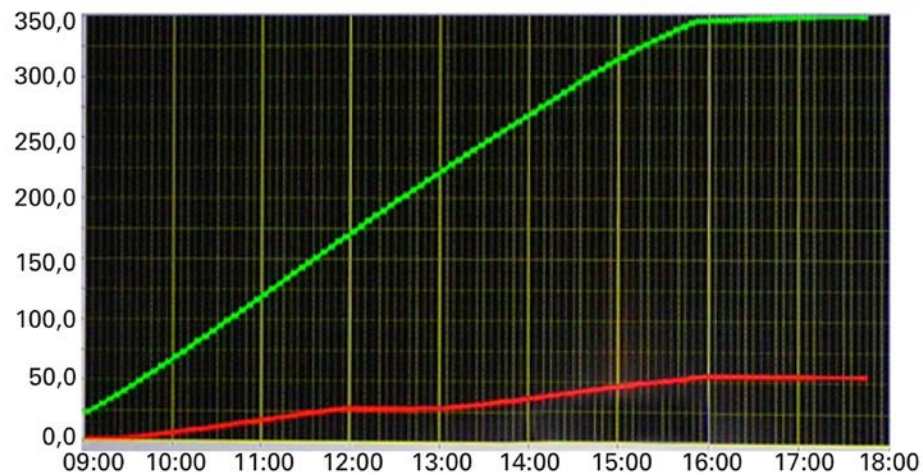



Projects



CHAIR LIFTS - DETACHABLE (CLD)

CLD 6 | Thaiwoo | CN | p. 32
CLD 6 | Bjelasnica | Sarajewo | BH | p. 40
CLD 4 | Crans Montana | CH
CLD 6 | Corvatsch | Curtinella | CH | p. 44
CLD 6 | Lavandinas | Laax | CH | p. 54
CLD 6 | Lauchernalp | CH | p. 38
CLD 6 | Oberalp-Calmut | CH | p. 46
CLD 6 | Schwamm-Wissi Stei | Pizol | CH | p. 42
CLD 6 | Mont Valaisan | La Rosière | FR | p. 36
CLD 6 | Moulins | La Rosière | FR | p. 37
CLD 6 | Le Corbier | FR | p. 34
CLD 6 | Mont Blanc | Les Arcs | FR
CLD 6 | Arpette | Les Arcs | FR
CLD 6 | Serre Chevalier | FR
CLD 6 | Fontaine Froide | Val d'Isère | FR | p. 56
CLD 6 | Marmottes Express | Val d'Isère | FR
CLD 6 | Boismint | Val Thorens | FR | p. 48
CLD 6 | Passo Tonale | IT
CLD 6 | San Domenico | IT | p. 50
CLD 4 | Kopa Karpacz | PL
CLD 6 | Rusinski | PL | p. 52
CLD 6 | Złoty Groń | PL | p. 58
CLD 4 | Illgaz | TR



CHAIR LIFTS - FIX (CLF)

CLF 2 | Bariloche | AR
CLF 4 | Bjelasnica | Sarajewo | BH | p. 62
CLF 2 | Amden-Niederschlag | CH
CLF 2 | Arvenbühl | Amden | CH
CLF 2 | Beckenried | CH
CLF 2 | Bergün | CH
CLF 3 | Bürchen | CH
CLF 2 | Bürglen | CH
CLF 3 | Brienz | CH
CLF 4 | Corvatsch Mandras | CH | p. 64
CLF 2 | Schatzalp | Davos | CH
CLF 1 | Eschbach | Einsiedeln | CH
CLF 2 | Flumserberg | CH
CLF 3 | Grimmelalp | CH
CLF 2 | Hintergoldingen | CH
CLF 2 | Hühnerköpfe-Furggabüe | Chur | CH
CLF 2 | Klosters | CH
CLF 2 | Krummenau | CH
CLF 4 | Lenzerheide Ost-West | CH | p. 65
CLF 2 | St. Peter | CH
CLF 2 | Unterbäch | CH
CLF 5 | Chillan | CL
CLF 4 | Hahnenklee | DE | p. 66
CLF 4 | Lorica | IT | p. 63
CLF 4 | Druskininkai | LT
CLF 4 | Chrzanow | PL

CLF 4 | Kielce | PL
CLF 4 | Lustyk Karpacz | PL | p. 68
CLF 4 | Poniwiec | PL | p. 67
CLF 4 | Kirovsk | RU | p. 69
CLF 4 | Ilgaz | TR



TÉLÉPORTÉ MIXTE (TPM)

TPM 4/8 | La Berra | CH | p. 28
TPM 6/8 | Altay | CN | p. 24
TPM 4/8 | Kopa-Karpacz | PL | p. 22
TPM 6/8 | Kirovsk | RU | p. 26
TPM 4/8 | Moscow | RU | p. 20



GONDOLA LIFTS (GLD)

GLD 4 | Arosa | CH
GLD 8 | Lenzerheide | CH | p. 16
GLD 8 | Vaujany | FR | p. 10
GLD 8 | Kish | IR
GLD 8 | Lorica | IT | p. 14
GLD 8 | Gangwha | KR | p. 8
GLD 8 | Vivaldi Park | KR | p. 12
GLD 10 | Narvik | NO | p. 6

Projects



AERIAL TRAMWAYS (AT)

AT 45 | Chur | CH | p. 88
AT 30 | Dallenwil | CH
AT 6 | Frömsen | CH | p. 72
AT 35 | Leukerbad | CH | p. 80
AT 60 | Moléson | CH | p. 82
AT 15 | Vetruse | CZ | p. 86
AT 60 | Brest | FR | p. 74
AT 15 | Les Arcs | FR | p. 76
AT 25 | Durango | MX | p. 84
AT 35 | Puebla | MX | p. 78



FUNITEL (FU)

FU 40 | Val Thorens | FR | p. 92



GROUP LIFTS (GRL)

GRL 2x2x4 | Malans | CH
GRL 2x3x6 | Huilo Huilo | CL | p. 96
GRL 2x2x4 | Santa Cruz | CL
GRL 2x2x18 | Limon | CR | p. 100
GRL 2x3x6 | Monteverde | CR | p. 101
GRL 2x2x10 | Druskininkai | LT | p. 98



INCLINED LIFTS (IL)

IL 15 | Chamonix | CH | p. 104
IL 15 | Sasso San Gottardo | CH
IL 8 | Zermatt | CH | p. 107
IL 12 | Gdynia | PL | p. 106
IL 10 | Asya Termal | TR



SKI LIFTS (SL)

SL Parque Caviahue | AR
SL Villa La Angostura | AR
SL Amden | CH
SL Chur | CH
SL Fideris | CH
SL Flumserberg | CH
SL Kaltbrunn | CH
SL Kandersteg | CH | p. 118
SL Lenzerheide | CH
SL Maloja | CH
SL Mollis | CH
SL Pian Cales | San Bernardino | CH
SL Pontresina | CH
SL Rabgiusa Furtschellas | CH
SL Rothenfluh | CH
SL Saas Grund | CH
SL Samedan | CH
SL Sternenbergl | CH

SL Tenna | CH | p. 120
SL Vulcan Bucon | CL
SL Ponte di Legno | IT
SL Presanella | IT | p. 119



SPECIAL ROPEWAYS

Material Lift Bad Aussee | AT | p. 111
Power Station Zervreila | CH
Rothenbrunnen | CH
Sils | CH
Wildhaus-Gamplüt | CH
World Expo Shanghai | CN
Grünten | DE



FUNICULAR RAILWAY

FR 250 | Vadistanbul | TR | p. 114



BARTHOLET MASCHINENBAU AG

Lochriet | 8890 | Switzerland
info@bartholet.swiss | T +41 81 720 10 60

BMF REMONTÉES MÉCANIQUES FRANCE SAS

9bis rue de la condamine | 38610 Gieres | France
bmffrance@bartholet.swiss | T +33 4 76 00 62 00

BARTHOLET KOLEJE LINOWE SP. Z O.O.

Wola Dalsza 369 | 37-100 Łańcut | Polska
biuro@bartholet-polska.pl | T +48 17 22 54 937

BRANCH OFFICE BARTHOLET MASCHINENBAU AG IN THE RUSSIAN FEDERATION

Leningradskiy av. 43A | 125167 Moscow | Russia
bmfrussland@bartholet.swiss | T +7 926 561 9292

BMF ROPEWAY GERMANY GMBH

info@bartholet.swiss | T +43 676 690 3462

BARTHOLET ITALIA SRL

f.balada@bartholet.swiss | T +39 34 5168 2252

BARTHOLET MASCHINENBAU AG

B.M.F BURSA TÜRKIYE

a.erbil@bartholet.swiss | T +90 224 242 09 00

BEIJING NORTH BARTHOLET ROPEWAY TECHNOLOGY CO., LTD

No. 5 Zhujiafen Wuli, Fengtai District | 100072 Beijing | China
bei.qiu@chinabnbr.com | T 010 83807166

SEARCH FOR THE



RECORDS